

**CANADIAN
COLLEGE OF
PHYSICISTS IN
MEDICINE**



**LE COLLÈGE
CANADIEN
DES PHYSICIENS
EN MÉDECINE**

CCPM Membership Examination

Edition 13.0

**MEDICAL PHYSICS QUESTIONS
FOR
MEMBERSHIP EXAMINATION**

Edition 13.0

Canadian College of Physicists in Medicine

**CANADIAN
COLLEGE OF
PHYSICISTS IN
MEDICINE**



**LE COLLÈGE
CANADIEN
DES PHYSICIENS
EN MÉDECINE**

CCPM Membership Examination

Edition 13.0

Medical Physics Questions For
Membership Examination
(Edition 13.0)

Questions de Physique Médicale
pour L'Examen d'Admission
(Édition 13.0)

Copyright © 2024 by the
Canadian College of Physicists
In Medicine

Copyright © 2024 par
Le Collège canadien des
physiciens en médecine

The CCPM Examination Booklets by [The Canadian College of Physicists in Medicine](#) are licensed under a [Creative Commons Attribution-Noncommercial-Share Alike 2.5 Canada License](#) (<http://creativecommons.org/licenses/by-nc-sa/2.5/ca/>).

Available from the:

Canadian College of
Physicists in Medicine

Disponible de:

Le Collège canadien des
physiciens en médecine

Mike Sattarivand, PhD, FCCPM, DABR, PEng, CRPA(R)
CCPM Registrar / Greffier du CCPM
registrar@ccpm.ca

Electronic version: ISBN: 0-9684873-3-5



FOREWORD TO THE THIRTEENTH EDITION

This is the thirteenth edition of the published question bank for the Canadian College of Physicists in Medicine (CCPM) membership exam. This is an exam to enable the CCPM to certify that those who pass the four-part written exam and three-part oral exam are competent in their medical physics subspecialty. Combined with credentialing for the exam, this is an exhaustive process into which a candidate is entering.

All question banks underwent significant updates in 2015 and are reviewed annually for suitability of the exam material. The Magnetic Resonance Imaging question bank was further updated in 2016, the Diagnostic Radiological Physics question bank was further updated in 2021. Significant updates to the Nuclear Medicine subspecialty exam were completed in 2023 with several redundant and/or out-dated questions removed and replaced with current/relevant questions; all the questions were reorganized to improve clarity. Smaller updates have been made to the current version of the Radiation Oncology question bank. Note that it is important to ensure that the correct question bank is downloaded when exam preparation begins! Much work has been invested in producing a comprehensive set of questions since 1984 thanks to the hard work of Past Chief Examiners: Ervin B. Podgorsak, Terry M. Peters, Gino Fallone, Ting-Yim Lee, Katharina E. Sixel, Michael D.C. Evans, Robert Corns, Boyd McCurdy, Renée Larouche, Alasdair Syme and Geneviève Jarry and all those who helped them.

A Preparation Guide now exists and is posted on the CCPM website. The Preparation Guide discusses time management strategies and the typical expected length of hand-written answers.

The College wishes to thank Alexandre Bourque, deputy examiner, as well as the many volunteers that help each year. A special thanks goes to Erin Niven and Marjorie Gonzalez who helped with the comprehensive revision of the Nuclear Medicine question bank.

Candidates preparing for their exam who have comments about the question bank are invited to contact me (chiefexaminer@ccpm.ca).

Best of luck to all of the candidates,

Marcus Sonier
Abbotsford, BC, Canada
September 30th 2024



CCPM Membership Examination

Edition 13.0

SUGGESTED TEXTS FOR PREPARATION OF THE EXAMINATION.

It must NOT be assumed that questions will be based solely on materials from these texts.

A: Radiation Oncology

1. The physics of radiation therapy: F. M. Khan; Williams and Williams, Baltimore.
2. Introduction to radiological physics and radiation dosimetry: P.H. Attix; Wiley, New York.
3. The physics of radiology (Fourth Edition.): H.E. Johns and J.R. Cunningham; Charles C. Thomas, Springfield Ill.
4. Modern technology of radiation oncology: J. Van Dyk (Editor); Medical Physics Publishing, Madison Wisconsin.
5. Radiation physics for medical physicists: E.B. Podgorsak; Springer, New York.
6. Radiation oncology physics: a handbook for teachers and students: E.B. Podgorsak (Editor); IAEA, Vienna.
7. Radiobiology for the radiobiologist: E.J. Hall; Lippincott Williams & Wilkins, New York.
8. ICRP publication 103: 2007 recommendations of the international commission on radiological protection, The International Commission on Radiological Protection; New York, 2007
9. NCRP report 147: Structural shielding design for medical x-ray imaging facilities: National Council on Radiation Protection and Measurements; Bethesda MD.
10. NCRP report 151: Structural shielding design and evaluation for megavoltage X- and gamma-ray radiotherapy facilities: National Council on Radiation Protection and Measurements; Bethesda MD.
11. CPQR Technical Quality Control Guidelines. <http://www.cpqr.ca/programs/technical-quality-control/>
12. ICRP publication 112: Preventing Accidental Exposures from New External Beam Radiation Therapy Technologies, The International Commission on Radiological Protection; New York, 2009

B: Diagnostic Radiology

1. Physics of radiology (2nd Ed.): A. Wolbarst, Medical Physics Publishing, Madison, WI; 2005
2. Review of Radiological Physics (3rd Ed.): W. Huda, R.M. Slone; Lippincott Williams & Wilkins; 2010
3. Essential Physics of Medical Imaging (2nd Ed.): J.T. Bushberg, J.A. Seibert, E.M. Leidholdt, J.M. Boone; Lippincott Williams & Wilkins; (2001)
4. Medical Imaging Signals and Systems: J.L. Prince, J. Links; 2005
5. Medical Imaging Physics (4th Ed.): W.R. Hendee, E.R. Ritenour; Wiley-Liss; 2002
6. Computed Tomography: Fundamentals, System Technology, Image Quality, Applications (2nd Ed.): W.A. Kalender; Wiley-VCH; 2006
7. Ultrasound Physics and Instrumentation (4th Ed): W.R. Hedrick, D.L. Hykes, D.E. Starchman; Mosby; 2004
8. Guidelines for the safe use of diagnostic ultrasound equipment. Prepared by the Safety Group of the British Medical Ultrasound Society Ultrasound 2010; 18: 52–59.
9. Medical electrical equipment – Characteristics of digital X-ray imaging devices – Part 1: Determination of the detective quantum efficiency. International Standard IEC 62220-1



CCPM Membership Examination

Edition 13.0

C: Nuclear Medicine

1. Physics in nuclear medicine (4th Ed): S.R. Cherry, J.A. Sorenson and M.E. Phelps; W.B. Saunders, Philadelphia; 2012
2. Nuclear medicine physics: L.E. Williams (Ed); CRC Press, Boca Raton.
3. The physics of radiology (4th Ed.): H.E. Johns and J.R. Cunningham; Charles C. Thomas, Springfield Ill.
4. Introductory physics of nuclear medicine, R. Chandra; Lea & Febiger, Philadelphia.
5. Radiation detection and measurement, G. F. Knoll; John Wiley and Sons, Third Edition, 2000.
6. Basic science of nuclear medicine, R.P. Parker, P.H.S. Smith, D.M. Taylor; Churchill Livingstone, New York.

D: Magnetic Resonance

1. Nuclear magnetic resonance imaging in medicine and biology: P.G. Morris; Oxford University Press, Oxford.
2. Magnetic resonance imaging: physical principles and sequence design, R.W. Brown, YN Cheng, E.M. Haacke M.R. Thompson, and R. Venkatesan, A. John Wiley & Sons, 2014.
3. In vivo NMR Spectroscopy: principles and techniques, R. A. de Graaf, John Wiley and Sons, 2007.
4. Questions and answers in magnetic resonance imaging, Second Edition, A.D. Elster and J. H. Burdette, Mosby, 2001.
5. Handbook of MRI pulse sequences, M. A. Bernstein, K. F. King, and X. J. Zhou, Elsevier Academic Press, 2004.
6. MRI: Basic Principles and Applications (4th Ed.); M.A. Brown, R.C. Semelka; Wiley-Blackwell; 2010
7. Principles of Magnetic Resonance Imaging: A Signal Processing Perspective, Z.P. Liang and P.C. Lauterbur, Wiley-IEEE, 1999



Section D: Magnetic Resonance Specialty

You will be required to answer **FOUR** questions from Part III and **FOUR** questions from Part IV. Total time for both questions is 2.5 hours. Each question is worth an equal percentage, totaling to 100% for each Part.



PART III MAGNETIC RESONANCE IMAGING SPECIALTY

1. Briefly discuss or define the following terms as they pertain to nuclear magnetic resonance (NMR):

(a) gyromagnetic ratio	(f) π and $\pi/2$ pulses
(b) Larmor equation	(g) chemical shifts
(c) T1	(h) local magnetic field
(d) T2	(i) dipole-dipole interaction
(e) FID	(j) magnetic field gradient

2. Discuss the Boltzmann distribution as it applies to proton NMR. What is the excess population of the lower Zeeman level of the protons in a glass of water at room temperature placed in a 1.5 T magnet? What is the spin temperature of a solid immediately after a π pulse? What is the spin temperature of a solid immediately after a $\pi/2$ pulse?

3. Define the rotating reference frame. Show that the effective magnetic field resulting from a z-directed stationary field \mathbf{H}_0 and a radiofrequency (RF) field \mathbf{H}_1 is time independent in the rotating frame. What is the effective field if the RF field is set at resonance?

4. State and discuss the phenomenological Bloch equations (in the laboratory reference frame) for the macroscopic magnetization in the presence of an applied magnetic field.

5. Define the spin-lattice and spin-spin relaxation times T1 and T2. Show the pulse sequences most often used to measure these parameters in an *in-vitro* NMR system.

6.
 - (a) Give typical T1's and T2's (measured at 1.5T) for:
 - i. bulk distilled water,
 - ii. grey matter,
 - iii. white matter,
 - iv. a hard tissue such as bone.
 - (b) Briefly describe how the T1 and T2 of water change after doping with a small amount of copper sulfate. What is the influence of the concentration of copper sulfate?
 - (c) What is meant by the term multi-exponential relaxation (use a sketch)? Which of the systems in part (a) would you expect to show multi-exponential magnetization evolutions? Why?



7. Plot the dependence of the spin-spin and spin-lattice relaxation times on the correlation time for bulk water assuming an isotropic reorientation relaxation mechanism (i.e., show the BPP curve for intramolecular bulk water relaxation). Identify three regimes with $\omega_0\tau \ll 1$, $\omega_0\tau \approx 1$ and $\omega_0\tau \gg 1$. Discuss the T1 and T2 dependence on magnetic field strength (the relaxation time dispersion) in each of these regimes.
8. Discuss the fast-exchange two-site model for tissue relaxation. What are the two “sites” which are considered to be exchanging? Which site dominates the tissue relaxation? Discuss this in terms of the observed tissue relaxation dispersion. How would the observed relaxation be changed if the exchange between the two sites were slow?
9. Usually the measurement of the decay of the FID is not sufficient to determine the spin-spin relaxation time of a tissue.
 - (a) Explain why this is the case.
 - (b) How do spin-echo pulse sequences correct this problem?
 - (c) Sketch the evolution of the magnetization during a $90^\circ - \tau - 180^\circ$ sequence to illustrate their use.
 - (d) What is the Carr Purcell (CP) pulse sequence?
 - (e) What is the Meiboom-Gill modification of the CP sequence and why is it an improvement over the CP sequence?
 - (f) What is the problem with CPMG measurements when the spacing between the 180° pulses is less than $T2^*$?
10. Paramagnetic agents can be used as relaxation contrast agents in tissues. Describe all terms and constants that you use in your discussion.
 - (a) What is the mechanism by which these agents work?
 - (b) The paramagnetic centers are dominant relaxation sinks for only a very small volume around the centers themselves; why is the relaxation of the whole tissue altered?
 - (c) Give the equation for the spin-lattice relaxation rate (T1) of an aqueous solution containing a paramagnetic salt.
11. The relaxation times measured *in vitro* by physics NMR spectrometers and *in vivo* by MRI systems often differ. Show that the signal observed in a typical T2-weighted image is a function of a number of NMR relaxation parameters and imaging parameters. Discuss other factors that may affect an MRI T1 or T2 measurement (e.g., R.F. pulses, field gradients, etc.)



12. It has been suggested that the spin-lattice relaxation time in the rotating frame, $T_{1\rho}$, may provide improved contrast in MRI. How do T_1 and $T_{1\rho}$ differ? What pulse sequence is used for a $T_{1\rho}$ measurement? Discuss possible MRI limitations with respect to R.F. power and specific absorption rate (SAR).
13. Briefly discuss or define the following terms as they pertain to NMR spectroscopy.
- | | |
|----------------------------------|-----------------------------|
| (a) hard pulse | (f) ppm |
| (b) spin-spin coupling | (g) Fourier transform |
| (c) NMR sensitivity of a nucleus | (h) reference standard |
| (d) proton decoupling | (i) outer volume saturation |
| (e) spectral editing | (j) polarization transfer |
14. The application of high-resolution ^{31}P spectroscopy to living tissue has been very successful. Discuss some of the features of this particular nucleus and the ^{31}P spectrum (e.g., NMR sensitivity, peak broadening, chemical shifts, spectral structure, etc), which make ^{31}P MRS attractive. Compare these features with those for proton MRS. Sketch a typical ^{31}P spectrum of muscle and label the different peaks; give their chemical shifts.
15. The chemical shift of the inorganic phosphate peak can be used to determine the internal pH of a tissue. Discuss the chemical basis of this technique, (in terms of the chemical exchange between species of organic phosphates) and the quantitative measurement of pH.
16. Discuss **ONE** of the following practical aspects associated with the implementation and interpretation of *in vivo* and *in vitro* MRS.
- The use of nuclear Overhauser effect (NOE) to increase signal intensity in MRS.
 - The problems in the maintenance of metabolic state in studies of excised tissue. Give a particular example with its solution.
 - The problems in localization of volumes of interest in *in vivo* MRS (e.g., determining volume probed, reproducibility for patient follow-up, etc.)
17. Discuss the advantages and disadvantages of ^{13}C NMR spectroscopy compared to ^1H NMR spectroscopy *in vivo*. The low natural abundance of ^{13}C can be exploited to study *in vivo* metabolic pathways by acquiring ^{13}C NMR spectra after the infusion of a ^{13}C -labelled substrate. Sketch the 25 ppm – 35 ppm range of a proton-decoupled ^{13}C NMR spectrum acquired from a human brain approximately an hour after the start of a $[1-^{13}\text{C}]$ glucose infusion. Assume no spatial localization and ignore any lipid signals from the scalp. Label all peaks and their chemical shifts. Draw and label a pulse sequence that could be employed to obtain the spectrum. What special hardware would be required for the procedure? Comment on any safety concerns associated with the sequence.



18. It has been suggested that, since the metabolism of neoplasms is different than that of normal tissues, MRS can be used to follow cancer treatment. Discuss some of the differences between brain proton spectra from normal and cancerous tissues. Sketch some examples. Describe some of the changes of the spectra subsequent to radiotherapy.
19. Draw a spin-echo sequence that can be used to measure water diffusion. Label all relevant components and timings. What is the gradient factor? Explain how the apparent diffusion coefficient can be determined from measurements acquired with the sequence. What is meant by isotropic and anisotropic diffusion? For each, give an example of an anatomical structure that exhibits that type of diffusion. How would you determine if a structure is anisotropic with the described sequence?
20. Discuss the following aspects of *in-vivo* MRS:
- The spatial localization of the MRS signals in terms of some of the parameters of surface coils. (e.g. ^1H homogeneity).
 - The difficulties in the quantification of *in vivo* MRS spectra.
 - The clinical problems associated with using MRS as a follow-up for patient response to therapy?
21. Nuclei other than protons are routinely used in NMR experiments and have been considered for *in vivo* measurements. Why do some nuclei have magnetic moments while others do not? Illustrate with an example of a nucleus having spin quantum number $I = 1$. State the spin quantum number and gyromagnetic ratio of free electrons; describe the reasons why it is more difficult to perform *in vivo* MR experiments on electrons than on routine nuclei.
22. Complete the following table with data for at least five additional nuclei which could be useful *in vivo*. Combine the middle three columns to estimate detection sensitivity at constant magnetic field compared to protons (= 1.0). List applications for each nucleus (not limited to endogenous concentrations).

Nucleus	Spin I	γ [10^6 rad/s/T]	Natural Abundance [%]	Relative Sensitivity
^1H	$\frac{1}{2}$	267.52	99.9844	1



23. Sketch *in vivo* proton spectra acquired from healthy and from cancerous prostate tissue. Label the peaks and their chemical shifts. A PRESS (Point RESolved Spectroscopy) sequence with optimized echo times can be employed to obtain spatially localized signal from the prostate. Please sketch the pulse sequence. For what purpose are the timings optimized? Discuss the challenges associated with *in vivo* spectroscopy of the prostate compared to that of the brain. How can these challenges be overcome?
24. Describe in detail a pulse sequence that would allow the ^{31}P NMR spectrum to be obtained only from a 2 cm^3 volume in the brain. Sketch a typical pulse sequence that could be employed to achieve this goal. Discuss the limitations of this approach.
25. Explain the nature of the appearance of blood flowing perpendicularly into a single slice with the following sequences (no flow compensation):
- (a) long TR, long TE, spin-echo
 - (b) long TR, short TE, spin-echo
 - (c) long TR, long TE, field-echo
 - (d) short TR, short TE, field-echo
- Discuss how the images would change using flow-compensated sequences.
26. Describe the artifacts that you might observe due to pulsating blood in the following sequences, and discuss two methods that might be used to minimize these effects.
- (a) long TR, long TE, spin-echo
 - (b) long TR, short TE, spin-echo
 - (c) long TR, long TE, field-echo
 - (d) short TR, short TE, field-echo
27. Describe techniques to perform TWO of the following three tasks. You may consider 3-D acquisitions.
- (a) selective qualitative 3-D imaging of the carotid arteries in the neck.
 - (b) phase-contrast imaging of the cerebral vessels.
 - (c) quantitative flow-imaging of the aorta.
28. Describe, with aid of timing diagrams using a spin-echo technique as an example, the two-dimensional Fourier transform approach to NMR imaging. Sketch the k-space trajectory.



29. Sketch the RF pulse and gradient waveforms of the following imaging techniques
- saturation recovery (partial saturation)
 - inversion recovery
 - field (gradient) echo
 - turbo spin echo
 - balanced steady-state free precession
30. For each of the techniques i–v listed below, state if and how, good image contrast can be achieved between tissues of
- different T1;
 - different T2;
 - different proton density.
 - saturation recovery (partial saturation)
 - inversion recovery
 - field (gradient) echo
 - turbo spin echo
 - balanced steady-state free precession
31. Describe the BOLD effect that is exploited to image function in the brain with MRI, and outline an imaging sequence that is sensitive to this effect.
32. Explain the fringe field of an MRI magnet. Give typical dimensions of the fringe field for an unshielded 1.5T whole-body MRI magnet. Describe two methods that can be used to reduce these fringe field dimensions and discuss the advantages and disadvantages of each.
33. List the major effects of the fringe magnetic field of an MR imaging system on the surrounding environment.
34. Discuss the importance of RF shielding of the magnet suite. What is the range of frequencies that have to be screened? What precautions must be observed when designing an RF shielded room? What is an appropriate value of RF screening effectiveness required for MRI and how is it measured?
35. MR imaging and in-vivo spectroscopy require different levels of field homogeneity and temporal stability. Discuss the requirements for body imaging (400 mm field size, 256x256 matrix) and spectroscopy, both performed on a 1.5 tesla magnet. Describe methods that might be used to achieve the above levels of homogeneity in each case.



36. Compare and contrast international and Canadian guidelines on:
- the maximum static B_0 field
 - the maximum rate of change of this field
 - the maximum average heating due to absorption of radiofrequency energy for head and body imaging.
 - the maximum sound pressure
37. Discuss the potential dangers to a patient who has been improperly screened for the presence of metallic objects prior to entering an MRI magnet room. What is the potential problem presented by a patient with:
- aneurysm clips,
 - metal hip prosthesis,
 - ear-rings?
38. Discuss some of the limitations imposed on MRI as an imaging device, by virtue of the strong magnetic field in and around the magnet. Make a list of instruments that will not operate satisfactorily in such a field.
39. Describe the mechanism of a magnet 'quench'; the precautions that can be taken to avoid such an occurrence and the procedure for evacuating the patient should such an event happen during a scanning session.
40. Let $B_1(t) = A \times \Lambda\left(\frac{t-0.5\tau}{0.5\tau}\right)$, where the triangle function $\Lambda(t)$ is defined as

$$\Lambda(t) = \begin{cases} 1 - |t| & \text{for } |t| < 1 \\ 0 & \text{otherwise} \end{cases}$$

If B_1 is applied in the presence of a magnetic field gradient applied in the z direction, G_z , derive an expression for the transverse magnetization at time τ using the small tip-angle solution.

41. Consider a nonselective excitation in which a constant pulse of amplitude B_1 and duration τ is applied in the presence of only B_0 . If the excitation frequency ω is not exactly tuned to ω_0 (i. e. $\omega \neq \omega_0$), determine the resultant transverse magnetization output at time τ . Use the small tip angle solution based in the frame rotating at the excitation frequency ω_0 .
42. Discuss the use of saturation pulses associated with an in-flow MR angiographic sequence, to eliminate signals from venous blood in the neck. Sketch an RF and gradient pulse sequence that would have this desired effect.



43. Consider the selective excitation pulse $B_1(t)$ plotted below in Figure (a). It is applied along x - and in the presence of a gradient magnetic field, G_z . The components of the magnetization distribution in the rotating frame, $M_{rot}(z)$, following this excitation pulse are plotted Figure (b). Reproduce the diagram in Figure (b) and label the three components shown.

For the selective excitations shown in Figures (c), (d) and (e) below, sketch the components $M_x^{rot}(z)$, $M_y^{rot}(z)$, $M_z(z)$ of the resultant distribution $M_{rot}(z)$. Although the tip angle is clearly 90° , use the small tip-angle approximation anyway.

For each of the three cases, comment on whether the results would still hold true if the small tip-angle approximation (which allows Fourier analysis of the pulse) was not assumed.

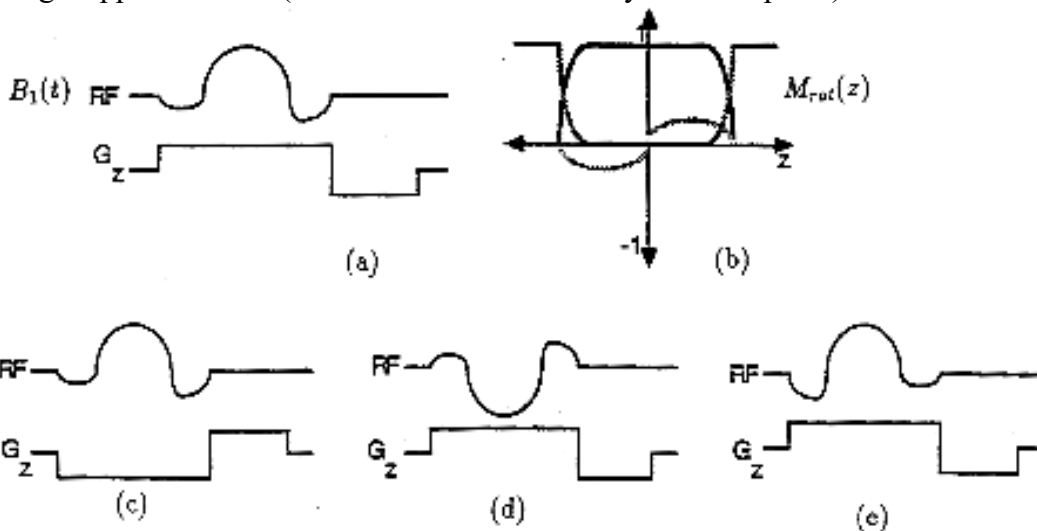

44. Solve the (differential) Bloch equation for the longitudinal component of the magnetization ($M_z(t)$) assuming a general initial condition $M_z(0)$.
45. Consider two materials A and B with the same M_0 but with relaxation time constants ($T1A, T2A$) and ($T1B, T2B$) respectively. Let $\Delta S_{xy} = M_{xy}^a(t) - M_{xy}^b(t)$ be the difference in transverse magnetization, and let $\Delta S_z(t) = M_z^a(t) - M_z^b(t)$ be the difference in longitudinal magnetization. Assume a 90° excitation.
- Find an expression for the time that maximizes ΔS_{xy} .
 - Find an expression for the time that maximizes ΔS_z .
 - Evaluate the expressions from parts (a) and (b) if the two materials are white brain matter and gray brain matter. (Specify the approximate values of T1 and T2 for the field strength that you are assuming in these calculations).



46. Discuss the effect, in the context of proton imaging, of chemical shift on the appearance of a typical image. Indicate the various procedures that may be used to minimize or eliminate its effects.
47. Describe a method of isolating a cubic volume within the brain, from which an NMR spectrum is to be obtained. Sketch a typical pulse sequence that could be employed to achieve this goal.
48. Discuss the modifications required to a standard imaging pulse sequence that would enable a spectroscopic image of a plane to be obtained. Describe the limitations of spectroscopic imaging.
49. Let the magnetization distribution $m(x, y)$ in an excited plane at $z = z_0$, be $m_0 \cdot \text{rect}(x/X, y/Y)$, where

$$\text{rect}(x, y) = \begin{cases} 1 & \text{for } |x| < 0.5 \text{ and } |y| < 0.5 \\ 0 & \text{otherwise} \end{cases}$$

For a "single-sided" (in k -space) projection-reconstruction sequence using FID signals, write a general expression for $s(t)$ when $G_x = G_{x0}$, $G_y = G_{y0}$. If $X = Y$, predict the FID signal $s(t)$ for

$$G_x = G_y = G \frac{\sqrt{2}}{2}$$

50. Let the magnetization distribution $m(x, y)$ in an excited plane at $z = z_0$, be $m_0 \text{rect}(x/X, y/Y)$, where

$$\text{rect}(x, y) = \begin{cases} 1 & \text{for } |x| < 0.5 \text{ and } |y| < 0.5 \\ 0 & \text{otherwise} \end{cases}$$

Determine the FID signal $s(t)$ for the 2DFT sequence (single-sided k -space acquisition) when G_y is turned on for t_y seconds before readout. For what value(s) of t_y is $s(t) = 0$? Explain from an object domain perspective why $s(t) = 0$.

51. In the most commonly used 2DFT imaging sequence, is the gradient G_y or lobe duration t_y incremented in order to perform phase encoding? Why is one preferred over the other? Describe and explain the image artifacts and other limitations that you might encounter if the wrong choice were made.



52. Consider the hypothetical situation of a modified 2DFT imaging sequence in which the 2D object is decomposed in one direction by its Hadamard components and not by its spatial frequency (Fourier) components. Such a weighting factor $W(y)$ is depicted below. Obviously a linear gradient field cannot produce $W(y)$.

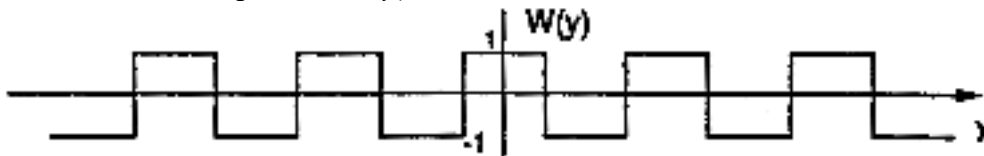

Plot a magnetic field function $C(y)$ (applied in addition to B_0) that will lead to the spatial weighting factor $W(y)$. If $C(y)$ is applied for time t_y , find an expression for the amplitude of this field. Are there other possible amplitudes? If imaging protons and $t_y = 1 \text{ ms}$, find a value for the amplitude of $C(y)$.

53. Three-dimensional imaging is generally performed with phase-encoding in two directions, and frequency encoding in the third. Describe a sequence that performs frequency encoding in the x direction; phase-encoding in the y direction and Hadamard encoding in the z direction using standard linear gradients. Include quantitative relationships such as gradient and RF pulse shapes.
54. An RF pulse $B_1(t)$ in the presence of G_z excites a slice in a uniform object (see below). Immediately following the excitation, the slice-select gradient is switched from $+G_z$ to $-G_z$ and a signal is recorded. Sketch the resultant signal that is read out during the $-G_z$ interval. Assume a small tip-angle excitation. Justify your sketch with an explanation or derivation and describe a possible application of this sequence.

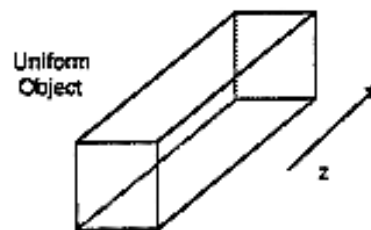
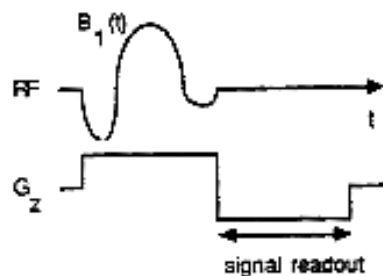



55. A nonselective 90° pulse applied along x - excites a uniform object. Following this excitation is a z -gradient pulse of amplitude G and duration T . Then, a nonselective -90° pulse along x - is applied. Plot the resultant $M_z(z)$ after this sequence. Ignore T_2 effects and assume $\omega = \omega_0$.

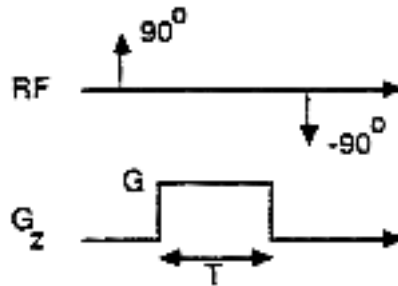

56. 2-D Fourier imaging is generally described in terms of *frequency* and *phase* encoding gradients. Using the **K-space** formulation, discuss how both these gradients are in reality performing a *phase-encoding* function. State the relationships between sampling in k -space, and image field of view and resolution.
57. Describe a dual-spin-echo (i.e. using 90° - 180° - 180°) 2DFT pulse sequence. Design the sequence so that the early-echo image corresponds to $TE_1 = 40$ ms and the late-echo image corresponds to $TE_2 = 100$ ms. Use a constant phase-encoding interval of 4 ms and for each echo acquisition, use a readout gradient interval of 8 ms centered about the echo. Draw a timing diagram and plot the k -space trajectory for this sequence. What are the required gradient strengths for the phase-encoding and readout gradients to achieve a 1 mm pixel size in the x and y directions in the reconstructed image?
58. Consider a constant RF excitation pulse of duration τ , tuned to the resonant frequency of water. At $B_0 = 1.5T$, determine the smallest value of τ such that the fat component is not excited. Assume the small-tip approximation. Using this value of τ what is the RF strength B_1 that produces a 90° tip angle? What is the physical basis for this fat-suppression technique?
59. Discuss the principle of the Turbo (or Fast) spin-echo (TSE) technique. Describe how T_1 , T_2 and proton density-weighted images are obtained with this approach. Comment on the differences that would be observed when comparing TSE images with regular SE images.



60. Given a saturation-recovery spin-echo sequence with a specified TE, find an expression for the TR that maximizes the difference signal between tissue A and tissue B. In general, tissue A has $T1 = T1A$, $T2 = T2A$, and tissue B has $T1 = T1B$, $T2 = T2B$. Assume they both have the same proton density and that $TR \gg TE$ and $TR \gg T2$. Compute the TR that maximizes the difference signal between brain white matter and gray matter at 1.5 T. Let $TE = 20\text{ms}$.
61. Given a saturation-recovery spin-echo sequence with a specified TR, find the expression for the TE that maximizes the difference in signal between tissue A and tissue B. In general, tissue A has $T1 = T1A$, $T2 = T2A$, and tissue B has $T1 = T1B$, $T2 = T2B$. Assume they both have the same proton density and that $TR \gg TE$ and $TR \gg T2$. Compute the TE that maximizes the difference signal between brain white matter and gray matter at 1.5 T. Let $TR = 3000\text{ ms}$.
62. Dr. T. claims that in a 2DFT spin-echo sequence, the baseband signal (the magnitude) peaks at time TE, the centre of the spin echo, for each phase-encode level. Dr. C. states that the maximum magnitude of the signal is at the center of the spin echo when the phase encoding lobe is zero but is not necessarily at the center for other phase-encode levels. Discuss the validity of these statements. You may use proofs, physical reasoning, examples, etc. Ignore T2 decay.



63. The object shown below consists of 1 cm by 1 cm square vials of water and lipid. Two images are acquired; the first with sequence (a) and the second with sequence (b). The TE for both sequences is the same. Sketch the image that results from subtracting image 1 from image 2. Assume the frequency of the water component is on-resonance, and that each image is scaled to its maximum.

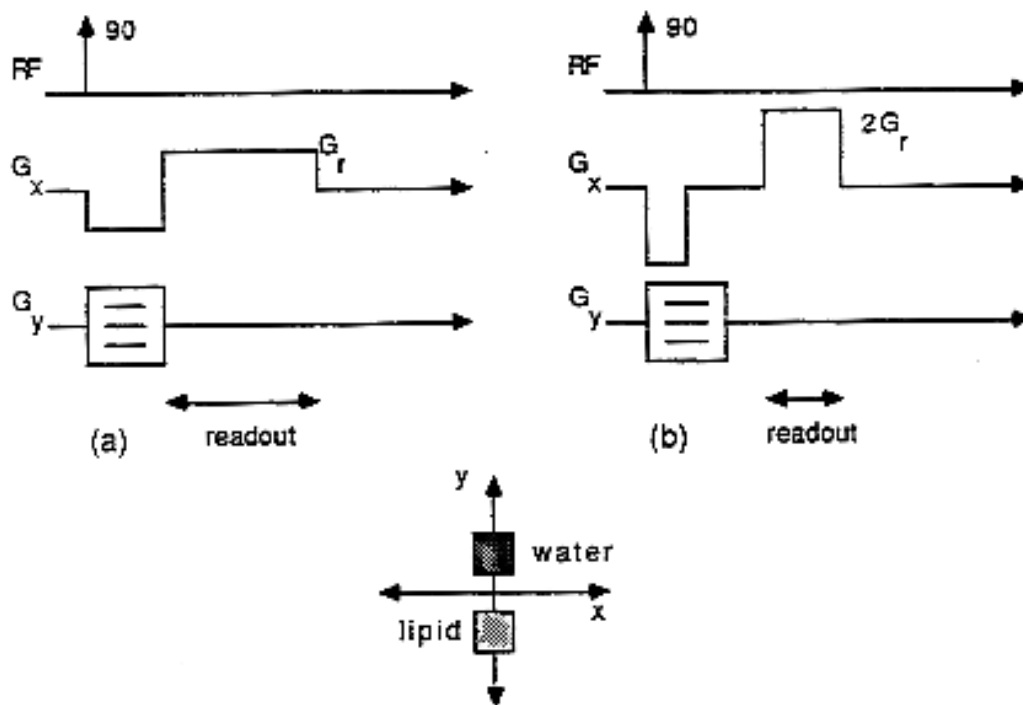

64. Sketch the 2D k -space trajectories for the following gradient time courses:

(a) $G_x(t) = At$; $G_y(y) = A$

(b) $G_x(t) = A\cos(2\pi ft)$; $G_y(y) = A\sin(2\pi ft)$

(c) $G_x(t) = A\cos(2\pi 2 ft)$; $G_y(y) = A\sin(2\pi ft)$

65. Consider a single-shot square spiral acquisition. Draw a labeled timing diagram showing the gradient waveforms applied and the resultant k -space trajectory. Assume idealized excitations. Relate image field of view and resolution to the gradient strengths and durations.



66. Examine the region of overlap in the aliased image of the figure below. Offer explanations for why the overlap occurs and why the image intensities in the region of overlap add to give lower signal intensity.

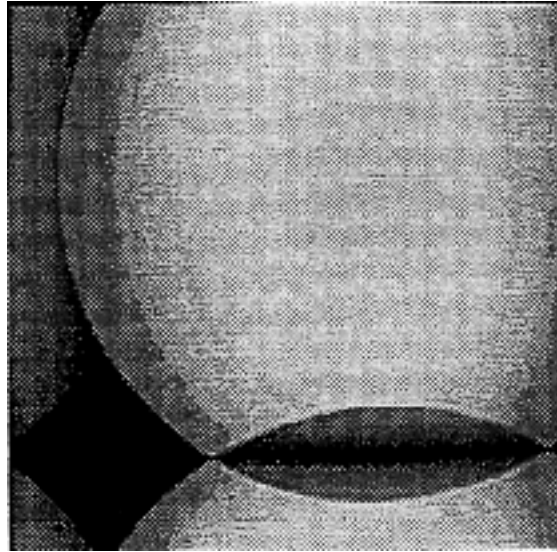

67. Consider a four-pulse sequence $\alpha_1 - \tau_1 - \alpha_2 - \tau_2 - \alpha_3 - \tau_3 - \alpha_4$.
- What is the maximum number of echo signals that can be generated?
 - What is the minimum number of echo signals that can be generated?
 - Derive the conditions for a) and b) to occur.
68. Draw an extended phase graph for the following excitation sequences, and for each case discuss how many echoes are generated.
- $90^\circ - \tau - 90^\circ - 2\tau - 90^\circ$
 - $90^\circ - \tau - 90^\circ - 1.5\tau - 90^\circ$
 - $90^\circ - \tau - 90^\circ - 0.5\tau - 90^\circ$
 - $45^\circ - \tau - 90^\circ - 2\tau - 90^\circ$
 - $45^\circ - \tau - 180^\circ - 2\tau - 180^\circ$



69. Assuming the following sequence was to be played out on a patient, describe how the resulting excitation would be distributed, and explain how the distribution is achieved. The width of the central lobe of each 3-lobe sinc function is 1 ms. Disregard relaxation effects. What is the maximum tip angle that may be present? Describe what practical uses this sequence or type of sequence may have.

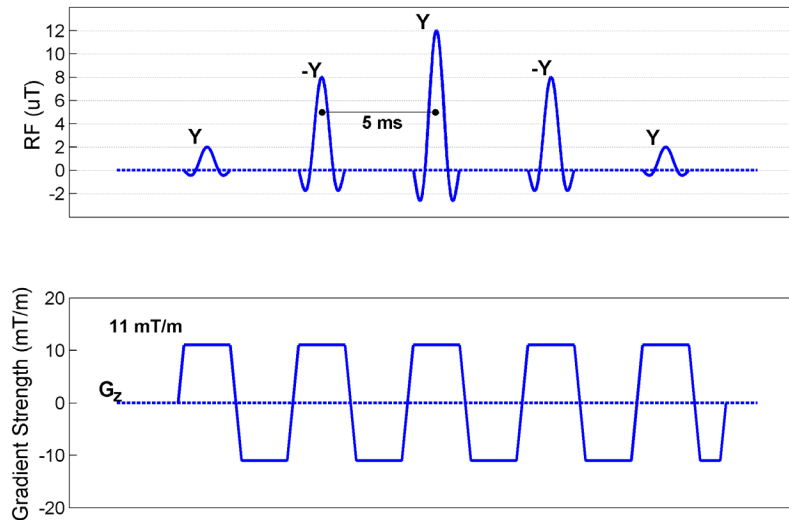

Note: $\int_{-2\pi}^{2\pi} \text{sinc}(x) \approx 2.84$

70. Identify and discuss the two general approaches to parallel imaging encoding and reconstruction. Give an example of each, and any associated advantages and disadvantages. List anatomical regions or imaging scenarios where one method may be preferable to the other, and explain why.



71. Consider a plausible turbo spin echo sequence with the following parameters:

- TR = 5 s
- Effective TE = 75 ms
- Flip angle = 90°
- Echo-train length (ETL) = 8
- Number of slices = 32 (maximum for TR = 5 s)
- Slice thickness and spacing between slices: 4 mm and 1 mm
- In-plane field-of-view = 320 mm
- Acquisition matrix = $N_{RO} \times N_{PE} = 256 \times 256$
- Total receiver bandwidth = 25 kHz

The sequence is used to image the thigh of a patient with a suspected tumor. You may assume the following relaxation times: T_1 (muscle) = 800 ms, T_2 (muscle) = 50 ms, T_1 (tumor) = 1200 ms, and T_2 (tumor) = 200 ms.

Discuss the changes in SNR, image appearance and contrast, and scan time that result when the technologist applies the following parameter modifications, keeping other parameters constant:

- (a) $N_{PE} = 192$
- (b) $N_{RO} = 512$, receiver bandwidth = 50 kHz, assuming a constant FOV
- (c) Field-of-view = 280 mm, keeping acquisition matrix constant
- (d) Excitation pulse flip angle = 60°
- (e) Slice thickness = 3 mm, no change in slice spacing

State any assumptions you make in your calculations with respect to the patient, such as relaxation times, etc.



PART IV MAGNETIC RESONANCE IMAGING SPECIALTY

1. List a few major medically used positron-emitting radionuclides and state their important physical characteristics, such as half-life, positron energy, etc. Identify and sketch the primary components of two devices that can be used to produce such positron-emitting radionuclides for medical purposes. Outline concerns regarding their use in the production of radiopharmaceuticals.
2. With the aid of sketches, describe, the geometry for longitudinal (restricted view angle) and transaxial (unrestricted view angle) single photon emission computed tomography (SPECT), giving details of the algorithms used to reconstruct images in each case.
3. Compare and contrast currently available positron emission tomography (PET) and single photon (rotating gamma camera) emission computed tomography (SPECT) with respect to spatial resolution, sensitivity (including realizable count rates), and ability to quantitate radioactivity. What physical phenomenon limits the current devices in these parameters?
4. Briefly define or explain:

(a) beta particle	(f) linear energy transfer (LET)
(b) alpha particle	(g) half-value layer (HVL)
(c) ionization	(h) positron decay
(d) K-absorption edge	(i) electron capture
(e) ion pair	(j) internal conversion
5. A very thin ultrasound transducer is backed with a material 1 cm thick. This assembly is then placed on a patient 10 cm away from a fat-like tumour. When the transducer is excited, a primary ultrasonic wave of amplitude 1.0 enters the tissue. At the same time, a secondary pulse of amplitude 1.0 enters the "backing", travels in the "backing", is reflected by the "air-backing" interface, and propagates into the tissue. The materials have the following properties:

Material	Z (kg/m ² s)	a (db/cm)	c (m/s)
tissue	1.63×10^6	1.00	1540
tumour	1.38×10^6	0.630	1450
backing	34.0×10^6	10.0	2000
air	4.00×10^2	12.0	331

What is the amplitude of the primary pulse at the tumour? What is the amplitude of the secondary pulse at the air interface? Calculate the amplitude of the secondary pulse at the tumour. Determine the relative magnitudes of the two pulses at the transducer after reflection at the tumour. What are the relative phases of these two pulses? How would the tumour appear in the image? What would you change to make the system better?



6. Define or discuss the following with respect to ultrasound imaging:
- | | |
|--------------------------|----------------------------|
| (a) piezoelectric effect | (f) pulse length |
| (b) matching layer | (g) aliasing |
| (c) acoustic impedance | (h) reverberation artifact |
| (d) scan converter | (i) duplex scanning |
| (e) B mode | (j) M mode |
7. Briefly define or explain each of the following parameters related to digital radiography:
- | | |
|--------------------------------------|-------------------------|
| (a) contrast transfer function (CTF) | (g) quantitative CT |
| (b) dual-energy CT | (h) saturation artifact |
| (c) ADC | (i) Hounsfield number |
| (d) pixel | (j) contrast media |
| (e) interlacing | (k) photoconductor |
| (f) bandwidth | (l) quantum noise |
8. Sketch and clearly label the primary components of a conventional film-based radiography system. Describe indirect flat panel detectors that have largely replaced film in general x-ray radiography.
9. Sketch and clearly label the primary components of the following systems and outline their advantages and disadvantages:
- | |
|---|
| (a) a conventional intensified fluoroscopy system |
| (b) a digital fluoroscopy system |
10. Discuss the procedures and equipment used in digital radiography to digitize the analog voltage signals that are produced by the video camera. Also discuss the effects of various digitization processes on the horizontal and vertical resolutions of the final analog image. Give typical values for resolution capabilities of conventional film-based radiography, conventional intensified fluoroscopy, digital fluoroscopy and scanned projection radiography.
11. The procedure most frequently performed using the digital fluoroscopy system is digital subtraction angiography (DSA). Discuss the rationale for, and procedures employed in, subtraction techniques in general and clearly state the advantages of DSA over conventional angiography techniques.



12. Briefly define or explain each of the following parameters related to digital radiography:
- | | |
|----------------------------------|------------------------------------|
| (a) spatial frequency | (g) Fourier transformation |
| (b) dark field | (h) automatic exposure control |
| (c) voxel | (i) exposure index |
| (d) CT water phantom calibration | (j) video frame |
| (e) flat field | (k) aliasing |
| (f) Wiener spectrum | (l) linearity of an imaging system |
13. Sketch and label the major components of a modern third-generation multislice CT scanner and outline with sketches the fundamental principles of CT, including data acquisition and image reconstruction.
14. Describe the radiation detector arrays used in current multislice CT scanners, including representative technical specifications and performance criteria.
- 15.
- Discuss the beam hardening effect in the context of CT imaging
 - Positron emission tomography (PET) images have the potential advantage of being quantitative. Prove that the correction for attenuation is independent of depth for a simple PET geometry
16. Discuss the implications of reconstructing CT images using data acquired using a helical scan protocol. Give typical numerical values for the following parameters as they pertain to CT imaging:
- x-ray tube kilovoltage
 - effective photon energy for the measured attenuation coefficients
 - the spatial resolution (at high contrast)
 - the image display matrix size
 - the image noise
 - the CT number values for: air, lung, fat, brain, water, trabecular bone, cortical bone
 - a typical effective dose for an abdominal CT scan.



- 17.
- (a) Discuss with sketches the concept of resolution and its measurement when it is defined by:
 - (i) smallest distance between two objects that can just be resolved as being separate in the image, and
 - (ii) the largest number of lines per millimeter on a bar pattern which could just be distinguished in the image.
 - (b) State for which of the following the image unsharpness cannot be specified by the line pair concept, and explain why:
 - (i) x-ray focal spot
 - (ii) x-ray film
 - (iii) intensifying screen
 - (iv) image intensifier
 - (v) TV camera
 - (vi) object motion
18. Define and sketch the Point Spread Function (PSF) and the Line Spread Function (LSF).
- (a) Discuss the technique for measurement of the two functions;
 - (b) Sketch experimental configurations for the LSF measurement of:
 - (i) image intensifier,
 - (ii) screen/film combination, and
 - (iii) x-ray film alone.
 - (c) Sketch typical LSF's for (i), (ii) and (iii) above, and discuss what effect, if any, the x-ray focal spot will have on the measurement of LSF.
19. Two basic factors determine the clarity of the radiographic image: radiographic contrast and image quality. The radiographic contrast depends on three factors: subject contrast, film contrast and scatter radiation plus fog.
- (a) Define subject contrast and discuss its dependence on the physical properties of the object and the radiation source;
 - (b) Define film contrast and discuss its dependence on the physical properties of the film, film processing, and radiation source;
 - (c) Discuss scattered radiation and fog and explain why they decrease the radiographic contrast.
20. The radiographic image quality is affected by quantum mottle, unsharpness and resolution.
- (a) Discuss in detail quantum mottle (noise) and explain how it is affected by the speed of a film-screen combination. Discuss the effect of film graininess on radiographic mottle.
 - (b) Discuss the sources of noise in digital radiography.
 - (c) Define unsharpness, sometimes referred to as blur. Discuss sources of blur in digital radiography.
 - (d) Define and discuss resolution and explain how it is measured. Also define the contrast transfer function (CTF) and show its relationship to resolution.



21. The imaging properties of an x-ray tube depend upon the focal spot.
 - (a) Illustrate by diagrams the change in geometric unsharpness with i) size of the apparent focal spot and with ii) magnification.
 - (b) Discuss the measurement of focal spot sizes using both a pinhole camera and by taking a radiograph of a star phantom. Compare the advantages and limitations of each method.
22. Discuss and show mathematically the relationship between the Point Spread Function (PSF), Line Spread Function (LSF) and Modulation Transfer Function (MTF) of a medical imaging system. Describe their relationship to image quality.
23. Define the Nyquist frequency for a digital imaging system and explain why undersampling causes aliasing. Give representative values of the Nyquist frequency for general radiography digital image receptors.
24. In digital (x-ray) projection radiography systems:
 - (a) Is it possible that the images are aliased? If yes, state the reasons why aliasing occurs by describing specific types of detectors and imaging tasks.
 - (b) If aliasing occurs in these images, how would you avoid it? Give specific examples and their implications on other aspects of the images.
 - (c) If aliasing occurs in these medical images, will the results be obvious to the eye? Whether yes or no, describe the appearance in the image and the reasons for your answer.
25. Define and describe the "Gibbs phenomenon" mathematically. Illustrate with a diagram its appearance in an image and give a specific imaging example in which the phenomenon appears.
26. You are presented with a cascaded three-stage imaging chain with the gains of each stage being g_1 , g_2 , g_3 respectively.
 - (a) Which stage must have the highest gain for the noise at the output to be lowest? Explain why.
 - (b) Which stage must have the highest MTF for the MTF at the output to be highest? Explain why.
27.
 - (a) Define noise equivalent quanta (NEQ) and describe the factors that influence the NEQ for a digital image.
 - (b) Define detective quantum efficiency (DQE) and describe the factors that influence the DQE for a digital radiographic image receptor.



28. Define and discuss :
- the Edge Response Function (ERF). Sketch the experimental arrangement for its measurement.
 - the modulation transfer function (MTF); explain its relationship to and advantages over the LSF and the ERF. Also clearly state the limitations of the MTF concept.
29. Discuss the techniques used for measurement of the MTF and sketch examples of MTF's for the following:
- film alone
 - focal spot
 - intensifying screens
 - image intensifier
 - a system containing all of the above.
30. Discuss the manner in which motion affects the system MTF. Include an expression that relates motion trajectory to blurring.
31. Draw a 2×2 matrix of disease (D+ or D-) and a diagnostic test (T+ or T-) for some patient population. Identify true positives, false positives, true negatives and false negatives and define the following terms:
- sensitivity
 - specificity
 - accuracy
 - prevalence of disease
 - predictive value of the test
32. Sketch a Receiver Operating Characteristic (ROC) curve and indicate the operating points on the curve corresponding to strict and lax thresholds. Explain the meaning of these thresholds and of the diagonal connecting (0,0) and (1,1) on the ROC plot. Discuss the use of the area under the ROC curve as a measure of the accuracy of a diagnostic test.
33. Describe the procedure used to perform an ROC study to compare the performance of two competing imaging modalities to diagnose a specific clinical problem.
34. Describe a "contrast-detail" analysis of an imaging system. Sketch and label a typical contrast-detail graph for a CT scanner. What are the major limitations of this technique?



- 35.
- (a) Describe how a Failure Modes and Effects Analysis is performed in an MRI clinic.
 - (b) For each of the following Failure Modes, identify one possible cause and suggest, with reasons, values for Frequency (F), Severity (S) and Detectability (D) parameters.
 - (i) incorrect patient for procedure;
 - (ii) incorrect MR scanning parameters used;
 - (iii) exam on patient with cardiac device.
 - (c) For each case in (b) above, what preventative measures could be employed to decrease D, (i.e. increase the detectability of the error before it reaches the patient)?
36. In relation to Radiology Information Systems (RIS) in running an imaging department, explain the purpose and use of:
- (a) firewall,
 - (b) checksum,
 - (c) IPv6,
 - (d) RAID,
 - (e) DICOM,
 - (f) PACS.